



INSTALLATION INSTRUCTIONS

LLOYD'S BUILDING – LONDON

SUPRA T1-T3-T5 T2-T4-T6

(fireman)

| | |
|---------|----------------|
| Code | GM.2.001050.EN |
| Version | F |
| Date | 18.04.2017 |

INSTRUCTION HANDBOOK FOR CONTROLLER



**COMPLIANCE
EN81 20-50**

safety in motion™

No part of this publication may be reproduced or translated, even in part, without prior written permission from WITTUR.

Subject to change without notice!

info@wittur.com
www.wittur.com

© Copyright WITTUR 2017



MIDI/SUPRA

Code GM.2.001050.EN
Version F
Date 18.04.2017

| | | |
|-------------|---|-------------|
| F | Updated document's Lay-out | 18/04/17 |
| | | |
| | | |
| | | |
| | | |
| E | Front page updated, modified pages 15, 16, 17 | 20/09/16 |
| | | |
| | | |
| | | |
| | | |
| D | Up-dated document's Lay-out and the following pages: 14; 16 | 08/10/15 |
| | | |
| | | |
| | | |
| | | |
| MOD. | DESIGNATION | DATE |

INDICE

| | |
|---|----------------|
| Symbols used and foreword | Pag. 2 |
| Warnings and suggestions | Pag. 3 |
| 1. General information prior to installation | Pag. 4 |
| 1.1 Description and function | Pag. 4 |
| 2. Electronic assembly layout..... | Pag. 4 |
| 2.1 Insulation test | Pag. 4 |
| 3. Commissioning | Pag. 5 |
| 3.1 Power Supply | Pag. 5 |
| 3.2 Safety Circuit | Pag. 5 |
| 4. Exchange of electronic box | Pag. 8 |
| 4.1 Preparation for learning of door parameters | Pag. 8 |
| 4.2 Driving the doors with the elevator controller..... | Pag. 9 |
| 4.3 Driving the doors by the service drive buttons | Pag. 10 |
| 4.4 Reset of coupler width | Pag. 10 |
| 4.5 Reset of all door parameters..... | Pag. 10 |
| 5. Adjustments always to be done | Pag. 11 |
| 5.1 Closing Force Adjustment | Pag. 11 |
| 5.2 Adjustment of the speed | Pag. 12 |
| 5.3 Setting speed according to Disabled People Regulations | Pag. 12 |
| 6. Description of LED's..... | Pag. 13 |
| 6.1 LED's Inputs | Pag. 13 |
| 6.2 LED's Outputs..... | Pag. 13 |
| 6.3 Different LED's | Pag. 13 |
| 7. Electrical Interfaces..... | Pag. 14 |
| 7.1 Inputs | Pag. 14 |
| 7.2 Passenger protection device input and supply..... | Pag. 15 |
| 7.3 Outputs | Pag. 15 |
| 8. DIP-SWITCHES..... | Pag. 16 |
| 9. Troubleshooting..... | Pag. 17 |
| 9.1 The door does not move | Pag. 17 |
| 9.2 The door does not reopen/reclose..... | Pag. 17 |
| 9.3 Faults causing reset or switch off (STATE LED is blinking) | Pag. 18 |
| 9.4 Faults decreasing performance of door | Pag. 18 |
| 10. Circuit diagram MIDI Drive (from 8/09) and SUPRA Drive (PS motor)..... | Pag. 19 |
| 10.1 With Detector (No EN 81-20)..... | Pag. 19 |
| 10.2 With W2D Photocell (No EN 81-20) | Pag. 20 |
| 11. Circuit diagram MIDI and SUPRA Drive for EN 81-20 | Pag. 21 |
| 11.1 With Detector EN 81-20 | Pag. 21 |
| 12. Wittur Programming Tool - Interface Software description..... | Pag. 22 |
| 12.1 Introduction | Pag. 22 |
| 12.2 Connecting the Wittur Programming Tool to the MIDI/SUPRA-electronic | Pag. 22 |
| 12.3 Menu structure of Programming Tool | Pag. 22 |
| 12.4 Door adjustment with the Programming Tool..... | Pag. 23 |
| 13. Default adjustment of MIDI/SUPRA software..... | Pag. 28 |
| 13.1 Default adjustments for MIDI drive | Pag. 29 |
| 13.2 Default adjustments for SUPRA drive | Pag. 29 |
| Warnings on how to keep the doors in good operating conditions..... | Pag. 30 |

The points that are important under the safety viewpoint and danger warnings are indicated with these symbols:



Danger general



Important warnings



Risk of personal injury (e.g. sharp edges, protruding parts)



Risk of damage to mechanical parts (e.g. incorrect installation)



Live parts

Congratulations on choosing a **WITTUR** product!

Before starting the installation of this product, read the information contained in this document.

Before installation work begins, it is in your own interests to clarify what structural and spatial conditions are available for installation work, so that you can see which installation procedures should/must be carried out. Therefore it is recommended that all circumstances be taken into consideration, and to mentally plan the installation sequence before any rash or badly planned work is carried out. Check the goods or parts for correct and full delivery upon receipt.

You will find important warnings on how to assemble and maintain your **WITTUR** product in good operating conditions and to get the maximum of your investment.

You will also find important information concerning the product care and maintenance which are an important factor to ensure safety at all times.

WITTUR has long been involved in research aimed at reducing noise level and in design that takes into due consideration the product quality and the conservation of environment.



This document is an integral part of the supply and must be available in the lift power room at all times.

All products are provided with identification type label and in case with certification marks in accordance with the current rules.

In case of need concerning the product, the identification data on the label must be always communicated to us. We hope you will get full satisfaction from this **WITTUR** product. Yours faithfully.

WITTUR

 **WARNINGS**

- WITTUR will not be held liable for any damage caused by tampering of the packing material by thirds.
- Before starting assembly, check that the product received corresponds to the order and to the packing list and that no damage has occurred in transit.
- Within its policy of continual research, WITTUR reserves to make changes to its products without notice. The figures, descriptions and data contained in this manual are intended as purely indicative and not binding.



- To ensure the safety of the product, avoid any alteration or tampering.
- WITTUR liability will be limited to the original components only.
- WITTUR product is intended for use in the lift sector only, therefore WITTUR liability shall be limited to such use.
- This product is intended for professional use. Any improper use, including for hobby or DIY, is prohibited.



- In order to prevent any injury to persons and damage to property, the handling, installation, adjustment and maintenance must be carried out by suitably trained personnel, using appropriate clothing and equipment.
- Any masonry work connected with the correct installation of the product must be executed in a workman-like manner according to the applicable laws.
- The connection of the electric/electronic units to the local power supply must be executed in a workmanlike manner according to the applicable laws.
- All metal parts supporting the electric/electronic units must be connected to an earth system in a workman-like manner according to the applicable laws.
- Before connecting the product to the power supply check that the product's requirement corresponds with the power supply available.
- Before starting any work on the electric/electronic components disconnect power from the system.
- WITTUR shall have no responsibility on the execution of masonry works or the connection of electric/electronic components to the power supply.
- WITTUR shall not be liable for damages/injury to property/persons caused by improper use of the emergency opening devices.



SUGGESTIONS

- Keep the material in the original packing, protected from bad weather and direct exposure to sun during the storage period in order to avoid the accumulation of water/condensation inside the packing material.
- Never dispose of packing material in the environment.
- Once dismantled, the product should be conveniently disposed as provided for by the local laws; never dispose of in the environment.
- Whenever possible, re-cycling is preferable to disposal in dump sites.
- Before re-cycling check the nature of the various materials and re-cycle in the appropriate way.



INSTALLATION TOOLS

Following tools are needed:

- "T"-handled hexagon keys 4 mm, 5 mm and 6 mm
- Screw drivers (flat and crossheaded)

The drive unit is preadjusted at the factory. No other mechanical and electrical adjustments other mentioned in this instruction are required at site!

 **DELIVERY**

Complete preassembled drive unit. Only to be stored in the original package (plastic wrap). The components must not be unpacked until the installation begins.

1. GENERAL INFORMATION PRIOR TO INSTALLATION

1.1 DESCRIPTION AND FUNCTION

MIDI/SUPRA car door operators are used for mid and high duty elevators. The Drive can move panel masses up complete door package weight to:

- MIDI up to 300 Kg
- SUPRA up to 700 Kg

2. ELECTRONIC ASSEMBLY LAYOUT

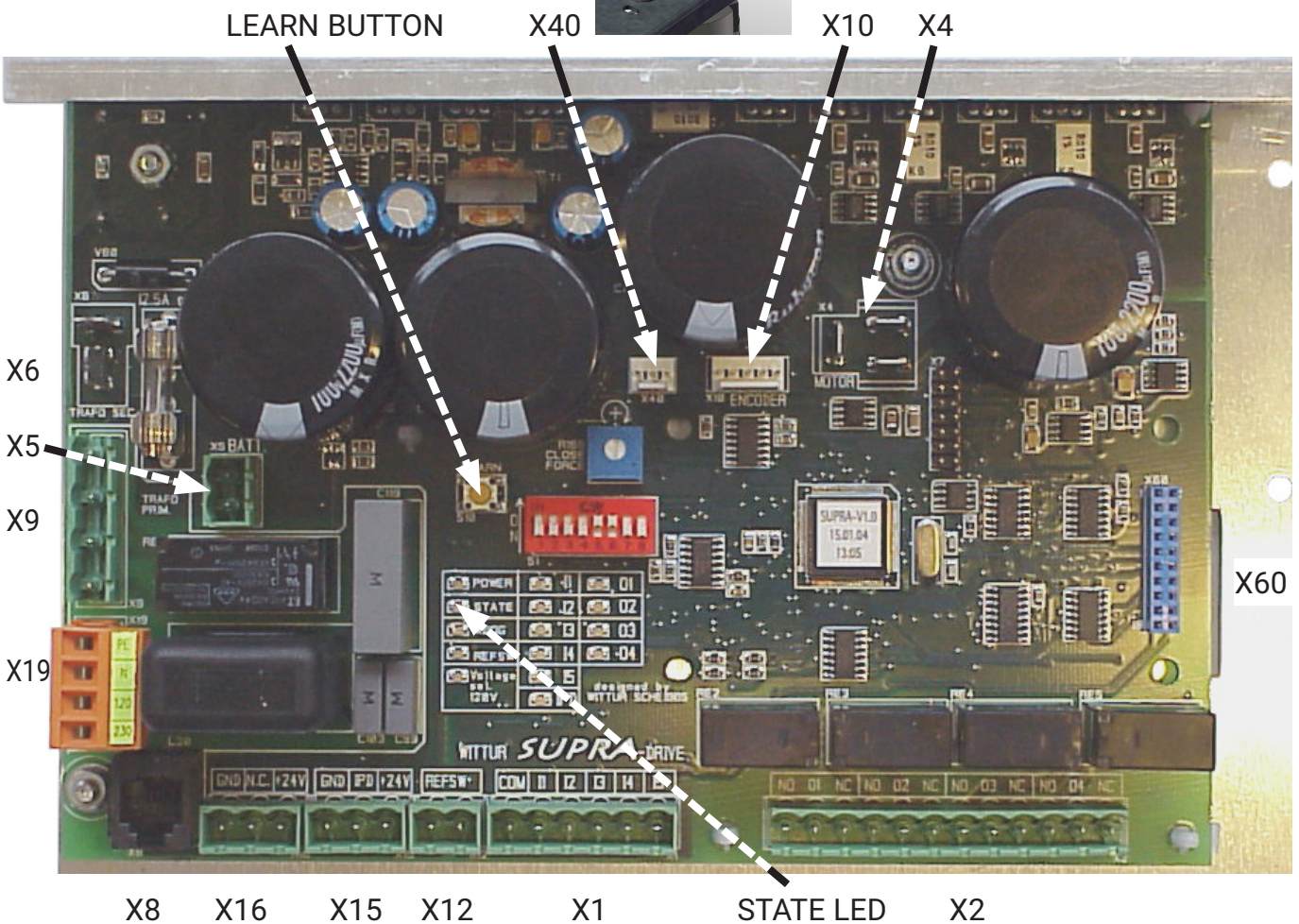

Plug description:

- | | |
|--|---|
| X1 - Inputs | X10 - Encoder |
| X2 - Outputs | X12 - Reference switch |
| X4 - Motor | X15 - Photo Cell (Curtain of light) Receiver |
| X5 - Battery supply (optional) | X16 - Photo Cell (Curtain of light) Transmitter |
| X6 - Transformer secondary winding | X19 - Board line-in connector |
| X8 - RS485 interface for WPT (Wittur Programming Tool) | X40 - Test drive buttons |
| X9 - Transformer primary winding | X60 - Extension plug |

2.1 INSULATION TEST

 **Caution:** Before carrying out tests on system's insulation, connector X5 must be disconnected.

3. COMMISSIONING

-  The door operators supplied directly from the factory are pre-adjusted: it is not necessary to carry out the door CO (Clear Opening) learning.
 The MIDI/SUPRA drive at first installation or after switch-off /switch-on will use the first two complete closing / opening cycles to optimize door CO: STATE LED off → CO optimized.

3.1 POWER SUPPLY

- The MIDI/SUPRA-drive is provided with a transformer for two different voltage ranges and can be supplied with 127VAC or 230VAC.
- Select the recommended fuse for the nominal voltage range, see table:

| | | |
|--|---------------------|-------------------|
| Nominal Supply Voltage Range: | 127VAC | 230VAC |
| Automatic fuse slow (in control panel) | 6A | 4A |
| Minimum cable required | 1,5 mm ² | 1 mm ² |

- Line in supply is connected to a terminal plug (X19).

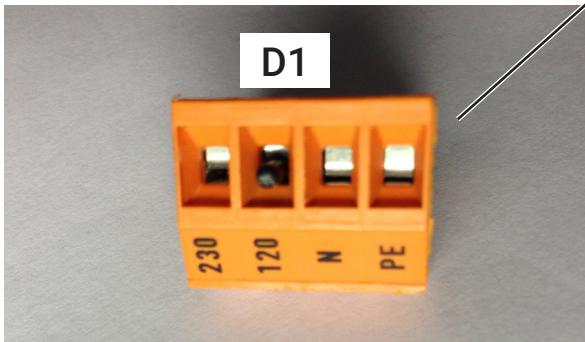

| | |
|---|----------------------------|
| PE = | Connect ground wire |
| N = | Connect neutral wire |
| 120 = | Connect 127 VAC phase wire |
| 230 = | Connect 230 VAC phase wire |
| Remove the plastic block before connecting the terminal 120 | |

3.1.1 Emergency supply

| | |
|------------------------|---------------------|
| Battery voltage | 24VDC-4Ah |
| Min. cable sq. measure | 1,5 mm ² |

- The battery's supply takes place through the X5 connector.

Pay attention: the battery has to be connected only in case of absence of the supply indicated on point 3.1.

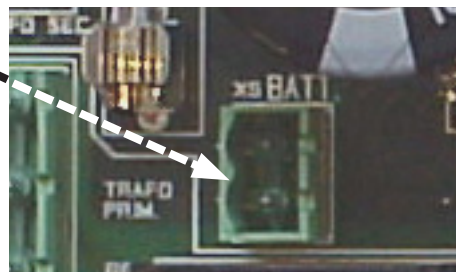

3.2 SAFETY CIRCUIT

- The door contacts are prewired to a terminal plug D2.
- Safety contact ratings: Min. 5Vdc - Max. 250Vac 2A

| | |
|--------------------|------------------------------|
| PE = | Connect ground wire |
| 1 & 2 = | Connect safety circuit wires |

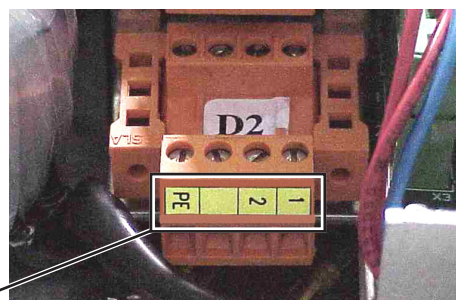

3.2.1 Emergency procedure in automatic mode (specialized technical staff not present):

If mains power is removed, to ensure correct operation of the emergency procedure in automatic mode via the control panel supplied by the buffer battery, it is necessary to supply the MIDI/SUPRA drive with power from a battery (24 Vdc 4 Ah) via connector X5 : the battery power must be supplied immediately after mains power is removed (the MIDI/SUPRA drive must not be switched off).

Door opening will be automatic (without the help of the lift controller), if relay K3 is used to activate input I1 (OPENING), or the lift controller will have to manage input I1 (OPENING) to activate door opening: Fig.1 recommended wiring diagram.

NOTE :

1. Input I1 is activated via contact K3 by a micro-switch installed inside the shaft. The micro-switch is activated by the arrival of the car to the floor where it was installed and the MIDI/SUPRA card will control input I1 via contact K3, only when powered by a battery.
2. If power is removed while the car is in line with the floor and the closing limit switch of the MIDI/SUPRA card is not activated, it will be possible to open the door manually at that floor, as the MIDI/SUPRA card will leave the motor unpowered.

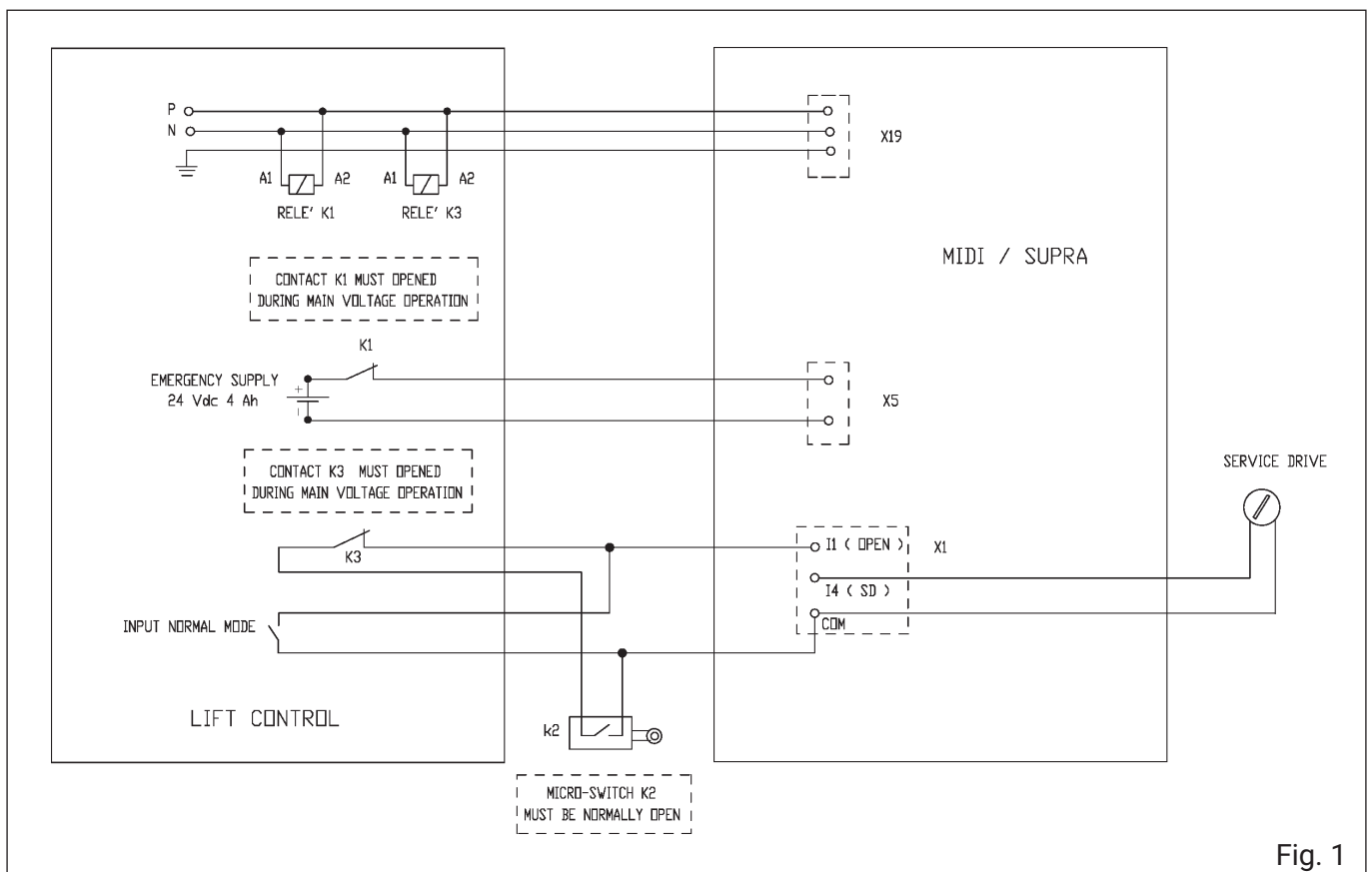

Fig. 1

3.2.2 Emergency procedure in manual mode (specialized technical staff present):

1. If mains power is removed, to ensure correct operation of the emergency procedure in manual mode, we recommend supplying the MIDI/SUPRA drive with battery power (24 Vdc 4 Ah) via connector X5 : the battery power must be supplied immediately after mains power is removed (the MIDI/SUPRA drive must not be switched off). This way it will be possible to align the elevator cabin with the desired floor by means of a manual operation: the doors can only be opened manually: Fig.2 recommended wiring diagram.

NOTE :

If the operator is equipped with retractable cam with car door locking, to ensure correct operation of the emergency procedure in manual mode, we recommend the possibility of removing battery power (e.g. via a manual or time-operated switch) when the cabin has been aligned with the desired floor manually: it will then be possible to open the doors manually without any problem.

If the MIDI/SUPRA card is not supplied with power from a battery (24 Vdc 4 Ah) via connector X5, the following situation will occur:

1. If there is an automatic operator with off-floor locking, the car can be manually aligned only to the nearest floor, as the floor lock will be opened by the retractable cams which will be extended to their maximum length due to the removal of power: the doors can only be opened manually.
2. If you have an automatic operator without off-floor locking, it will be possible to align the car with the desired floor using a manual procedure: the doors can only be opened manually. This is possible because the automatic operators without off-floor locking are fitted with a standard mechanic/magnetic device which allows the retractable cams to remain closed.

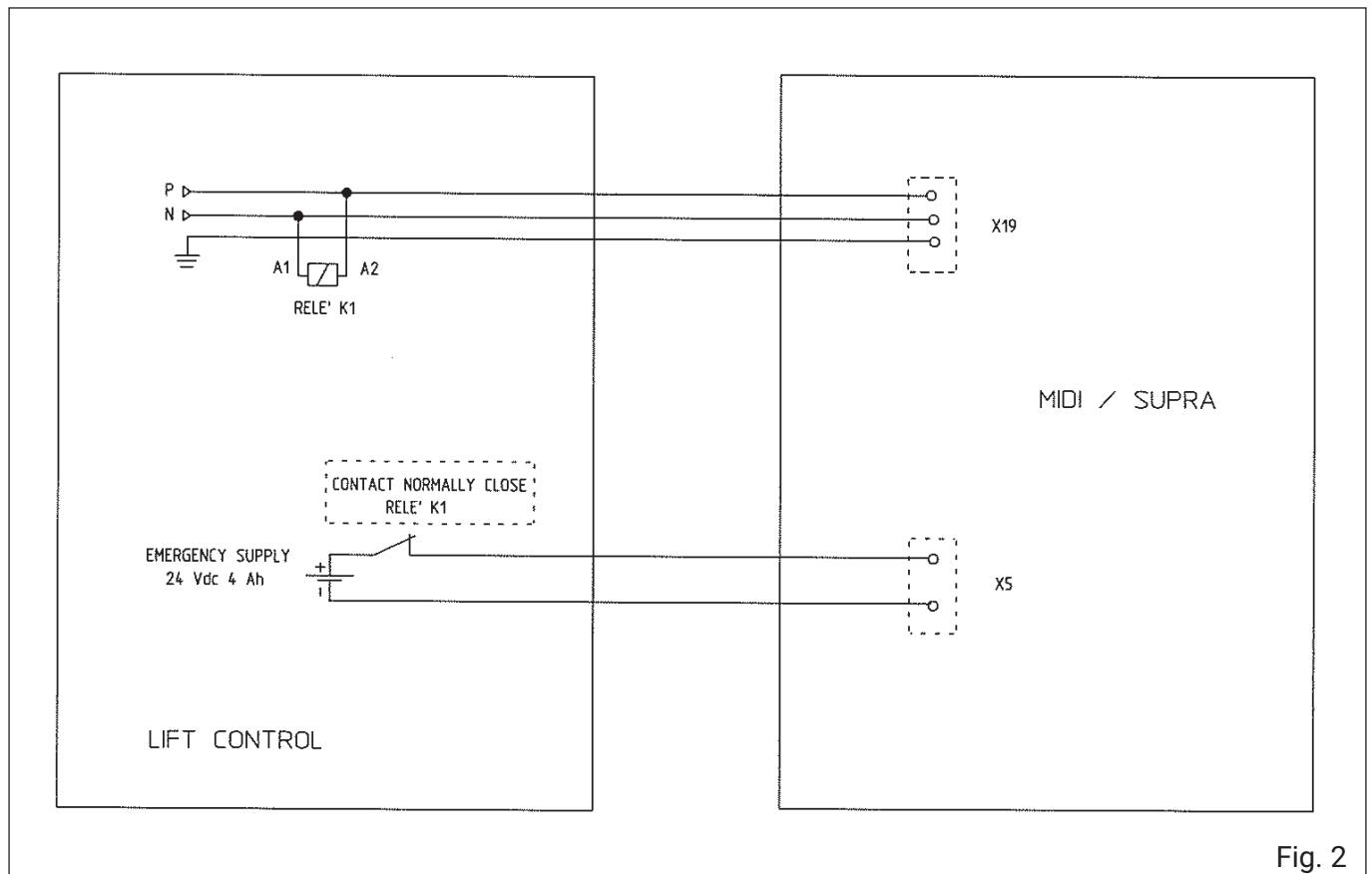



Fig. 2

4. EXCHANGE OF ELECTRONIC BOX

4.1 PREPARATION FOR LEARNING OF DOOR PARAMETERS

 Carry out only in event of replacement.

- 1 DIP-Switch setting has to be done according requirements, see chapter 8: "DIP-Switches".
- 2 In case of need adjust the reference switch so, that switch and magnet are opposite one each other when the door panels are closed (clearance 5-6 mm between switch and magnet should be 5-6 mm).

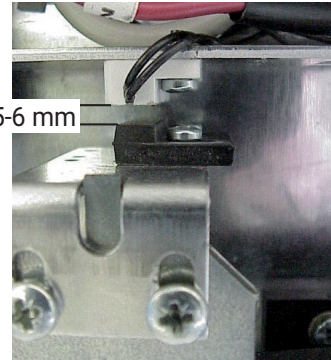

- 3 The DIP-Switch S1/1 (Test Taster Drive) must be activated.

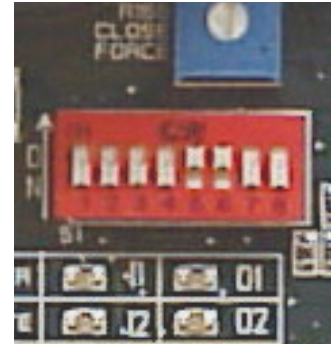

- 4  Set the panels of the car door in closing position (1) and ensure that the cams are rigorously open (2). Therefore open the door panels by hand and push them manually to closed position. The hanger plate (truck) must touch the close end buffer. See picture below (1).

Strut-Coupler System

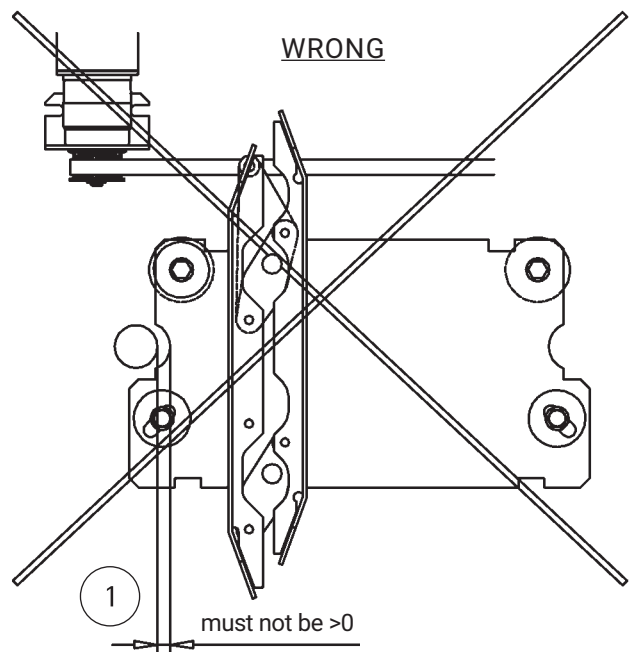
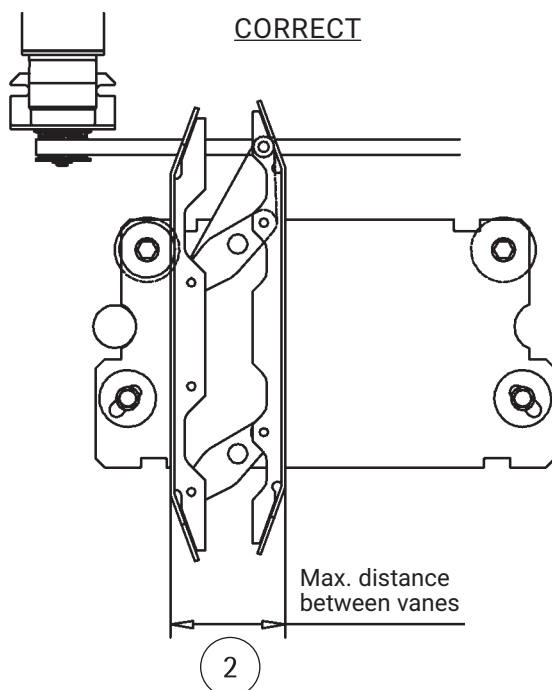

5 Through the terminal box (X19) activate power supply, as shown at par. 3.1.

 Press the LEARN push-button **for one second only**, immediately after switching on.



6 Now the door must be driven in close direction by use Test Drive Button.

7 The door might now run in wrong direction in respect to command. Use that test drive button which drives the door in close direction and drive until door panels are fully closed (REF SWITCH LED must be on).

8 If the motor is running in wrong direction the electronics rectifies the motor rotation direction when the "Ref Switch" is closed and a new learning procedure will re-start.



Is no reference switch available the direction of the motor rotation must be changed by double click of the learn button if necessary. Continue with item 6 afterward.

9 Now the learning of door width is done during 2 consecutive full door width movement cycles (STATE LED off -> learning done).



Take care that the commands are available in end positions for more than one second, that the electronic has time enough to detect the mechanical end position.

10 The parameters are stored automatically after learning procedure.

4.2 DRIVING THE DOORS WITH THE ELEVATOR CONTROLLER

- Connect the signals from the elevator controller to connector X1 and X2 of the door operator.
- Refer to the project delivery documents for the wiring diagram between the elevator controller and door operator (see also connection diagram in chapter 10 -> MIDI or chapter 11 -> SUPRA).
- Check if Test Button operation switch is OFF S1/1.

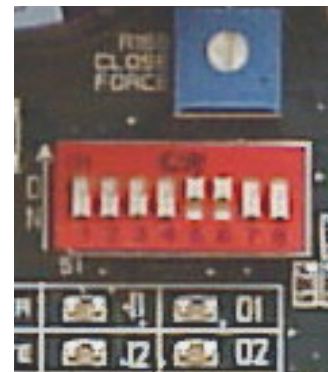

- If the door is not at the reference switch (near by close end, door panels closed) in power up and CLOSE is active (connected with COMMON) it will move at low speed as long as the reference switch (in close end) is found.
- After finding the reference switch or the mechanical close end the door drive will start with the next OPEN command in direction open with normal speed drive until the mechanical end is found.
- Then the door will drive with normal speed in both directions.
- Check that the safety devices (photo cells, light barrier or close force limiter) reopen the door (see DIP-switch description).
- According to the DIP Switch adjustment (S1/2) the door is reopend by the elevator control or automatically by the door itself (see chapter 9.2).

4.3 DRIVING THE DOORS BY THE SERVICE DRIVE BUTTONS

- The Test Buttons only work when the Test button operation switch (S1/1) is active (the inputs I1 Open, I2 Close, I3 Nudging, I4 and I5 are deactivated in this case)
- Check that the door is moving open and close when the test buttons are pressed.
- In this mode of operation the reopening of the door by a safety device is not activated (enables the adjustment of the closing force).

4.4 RESET OF COUPLER WIDTH

If the coupler parameter must be reset (e.g. remove or change of coupler system, coupler width wrong.....) continue like described below:



Before "Reset of coupler width" is done, do preparation for learning described in paragraph 4.1, item 1, 2, 3 and 4 (manual closing of door panels, but don't close coupler vanes!).

By pressing the learn button for at least 10 seconds (until State LED flashes fast) the coupler width is cleared and a new learning is started.

After resetting the coupler width, continue with start-up procedure like described in paragraph 4.1 "Learning of door parameter" starting with item 5.

4.5 RESET OF ALL DOOR PARAMETERS

(this function can only be activated by service tool only, see item "12.4.2.2 Reset to default").

If the door parameter must be reset to default (e.g. change of electronic from one door to another, removing or changing of coupler system.....) continue like described below:

Before "reset to default" is done, do preparation for learning, described in paragraph 4.1, item 1, 2, 3 and 4 (manual closing of door panels, but don't close coupler vanes!).

By pressing the LEARN button for at least 10 seconds (until State LED flashes fast) parameter coupler width is cleared and new learn cycle is started.

After resetting the door parameter, continue with start-up procedure like described in paragraph 4.1 "Learning of door parameter" starting with item 5.

5. ADJUSTMENTS ALWAYS TO BE DONE

5.1 CLOSING FORCE ADJUSTMENT



An adjustment of too high closing force may cause serious injury to passengers. The max. allowed force can be found in the code valid for your country (EN81: max. 150N).



The adjustment must be done by use of a force measuring device.



Do not attempt to measure the force of a moving door, stop it first to avoid damage of the force measuring device!

- Open and close the door manually and check that there is no mechanical obstruction.
- Put a force measuring device between the door panels (center opening) or between door panel and slam post (side opening).

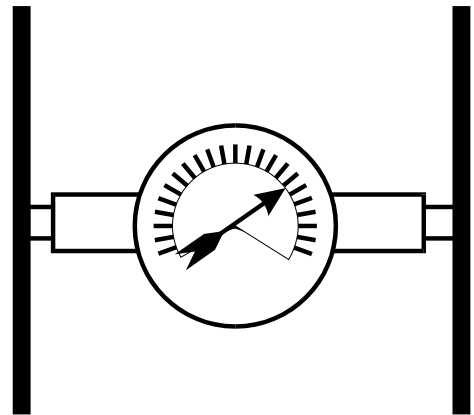

For centre opening the measuring device will show half of the actual close force. For side opening the measuring device will show the actual close force.

- Drive the door with the close button (or close command) to the close direction. The Test Buttons only function when the Test button operation switch (S1/1) is activated.
- The close command should be applied for less than 10sec period's, than remove the close command for a short time, before continue the adjustment procedure.

- Adjust the closing force according codes using potentiometer CLOSE FORCE. The Closing Force will increase by turning the potentiometer clockwise!

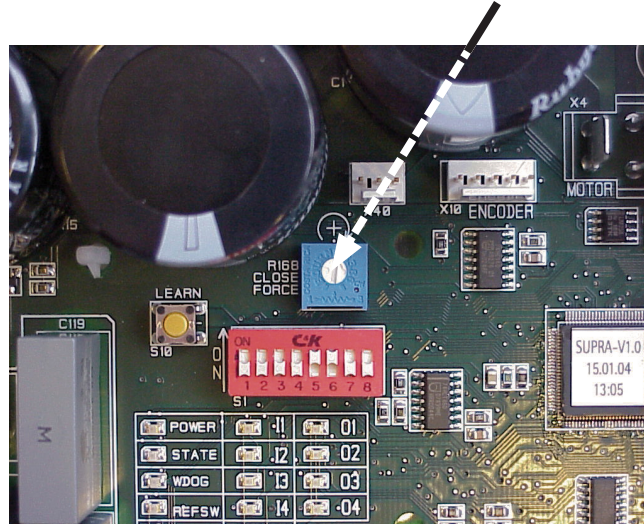

5.2 ADJUSTMENT OF THE SPEED

- The drive electronic offers to select one out of four different speed levels (for handicap elevators or other purpose).
- Look at DIP-SWITCH description (chapter 8).

5.3 SETTING SPEED ACCORDING TO DISABLED PEOPLE REGULATIONS

- The DIP-SWITCHES S1/5 and S1/6 must be set to OFF.

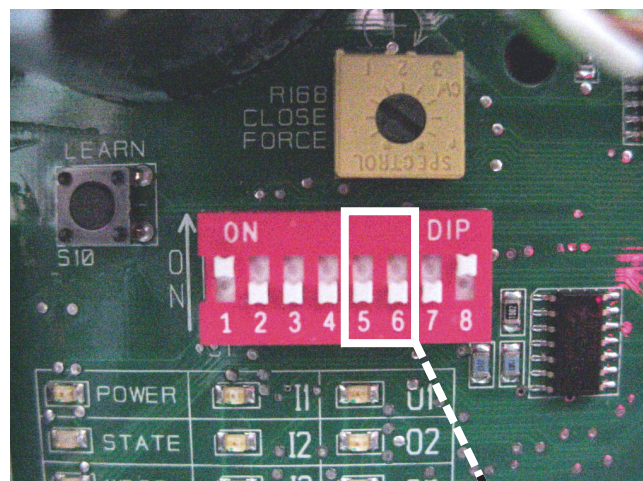

DIP-SWITCHES S1/5 and S1/6 SET TO OFF

6. DESCRIPTION OF LED'S

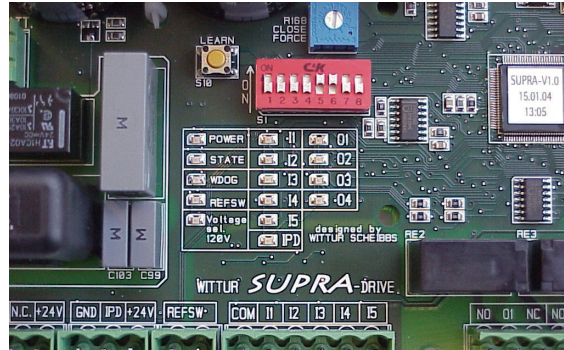

6.1 LED'S INPUTS

| Name | LED illuminated if |
|------|---|
| I1 | Input 1 is connected to COM |
| I2 | Input 2 is connected to COM |
| I3 | Input 3 is connected to COM |
| I4 | Input 4 is connected to COM |
| I5 | Input 5 is connected to COM |
| IPD | Input Passenger-Protection Device (Photo cell, ...) |

6.2 LED'S OUTPUTS

| Name | LED illuminated if |
|------|----------------------------|
| O1 | Output 1 relay is operated |
| O2 | Output 2 relay is operated |
| O3 | Output 3 relay is operated |
| O4 | Output 4 relay is operated |



6.3 DIFFERENT LED'S

| Name | LED illuminated if |
|------------------------|--|
| POWER | the power supply is switched on |
| WDOG | the microcontroller does not work |
| STATUS | Light: during start up and learning Flashes: if an error is detected 1x Motor / encoder fault 3x internal fault 4x abnormal operation 5x learning error Details see page 18, item 9.3 Off: normal operation |
| REFSW | the door is in close end switch area |
| VOLTAGE SEL. 127VAC | 127VAC supply voltage selected |

7. ELECTRICAL INTERFACES

7.1 INPUTS

The Inputs are activated if they are switched at COM.

| Terminal | Symbol | Name of the terminal | Explanation |
|----------|---|----------------------|--|
| COM | COM | COMMON | Common line for I 1..4 |
| I1 |  | OPEN | This command will drive the door in open direction until the open position is reached. Depending on the setting of DIP-Switch S1/8 the door is kept open by motor torque also without command. |
| I2 * |  | CLOSE | This command will drive the door in close direction until close position is reached and coupler is opened. Depending on the setting of DIP-Switch S1/8 the door is kept closed by motor torque also without command. |
| I3 | NDG | NUDGING | Nudging input, puts the door to slow speed drive in close direction. Smoke sensitive devices like photo cell or light barrier (Input IPD) will be ignored. |
| I4 | SD | SERVICE DRIVE | If set to TEST it enables the service keys. If set to RUN it enables the lift controller commands. |
| I5 | RSH | HIGH SPEED | By setting this input a higher speed can be selected. This input is active only when DIP-Switch S1/6 is switched OFF. |

* Attention:

- 1) To comply to new EN81-20 (5.3.15.1) standard it is mandatory that the elevator controller removes the "CLOSE COMMAND (I2 = OFF)" when parking/resting on floor level.
As a consequence the door operator motor is unpowered and ensures that the car door lock is in unlocked state.
- 2) While moving the elevator car it is mandatory that the "CLOSE COMMAND (I2 = ON)" is active to ensure that car door lock is in locked state.

SERVICE DRIVE SWITCH



- RUN position: accepts commands from operation panel,
- TEST position: accepts commands from service keys (X40).

N.B.: The **SERVICE DRIVE SWITCH** can be adjusted with a screwdriver; rotate clockwise/anticlockwise.

The DIP-SWITCH S1/1 must be strictly set in the OFF position.

Optical couplers are mounted on the inputs, supplied directly from the MIDI/SUPRA drive:

Technical data:

- Voltage: 24 VDC \pm 10 %
- Power: 12 mA each input



7.2 PASSENGER PROTECTION DEVICE INPUT AND SUPPLY

The Input is activated if it is connected to GND. The Input is activated if put at GND. For parameterset xE (EN81-20) the IPD input have to be active if no obstacle is detected by the detection device. See 10.3 Wiring Diagram for EN81-20.

| Terminal | Symbol | Name of the terminal | Explanation |
|----------|--------|----------------------|--|
| +24V | PH+ | +24V | +24V DC supply for photo cell or curtain of light (max. 150mA) |
| IPD | REV | PHOTO CELL | Input for Photo Cell or curtain of light, light barrier or other passenger protection device |
| GND | PH- | GND | Ground for supply of photo cell or curtain of light (light barrier) |
| N.C. | L | | Can be used as terminal for light barrier (no internal connection) |

7.3 OUTPUTS

The outputs are relays where the 3 connections of the contacts are feed to the terminals. (O1 to O4: COMMON = OX, normally open contact = NO, normally close contact = NC)

| Terminal | Symbol | Name of the terminal | Explanation |
|----------|---|----------------------|---|
| O1 |  | OPEN END | The open end output indicates the fully open position of door panels |
| O2 |  | CLOSE END | The close end output indicates the fully closed position of door panels |
| O3 | REV | REOPEN | The Reopen output indicates if a reopen request, coming from photo cell or close/open force limiter is pending or an automatic reopen/close is done. |
| O4 * | POS | Position | This output is set when the door is opened wider than a certain position (trigger point can be adjusted by WPT, normally deactivated) * With Parameter set E (EN81-20) the output O4 is set in reference area. |

Technical data:

- Voltage: 230 VAC / 30 VDC
- Power: max 2A continuous load

Subject to change without notice!

8. DIP-SWITCHES

| | ON | OFF |
|---------------|--|---|
| S1/1 | Test Button operation (buttons active) | Normal operation (command inputs on X1 active) Activate SERVICE DRIVE SWITCH |
| S1/2 ***** | Automatic reopen/reclose on obstruction or IPD (Reopen O3 is switched as long as reopen/reclose is) | No automatic reopen/reclose (only Reopen O3 is switched) |
| S1/3 ** | Electric shoe operation, command input always I1 (swing door mode)(*) | Normal operation (command inputs on X1 active) |
| S1/4 | Reduced motor torque is used | Maximal possible motor torque is used |
| S1/5 | Speed selection, binary coded, see figure | |
| S1/6 | | |
| S1/7 **** | Open force limitation active | No open force limitation |
| S1/8 *** | Automatic end keeping | Hold open/closed only on active open/close command |

(*) Mode 1:
I1 = ON -> door opens
I1 = OFF -> door closes

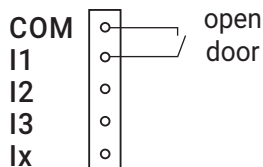

(*) Mode 2:
I1 = ON -> door closes
I1 = OFF -> door opens

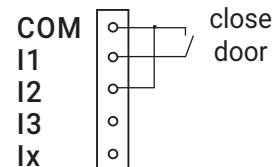

SPEED ADJUSTMENT

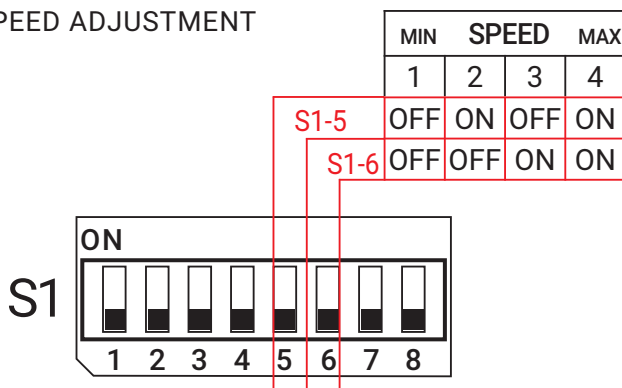

- ** For the compliance to EN81-20 (part. 5.3.15.1) the switch S1/3 must be OFF
- *** For the compliance to EN81-20 (part. 5.3.15.1) the switch S1/8 must be OFF
- **** For the compliance to EN81-20 (part. 5.3.6.2.2.1 only glass doors) the switch S1/7 must be ON
- ***** In case of automatic reopen/reclose, O3 is set if an obstacle is detected and switch off after reopen/reclose
In case of no automatic reopen/reclose, O3 switch on when an obstacle is detected and switch off when the obstacle is removed or a reopen/reclose command is applied from the liftcontroller.

9. TROUBLESHOOTING

There is a fault if the State LED is blinking. The faults can be read by WPT.

9.1 THE DOOR DOES NOT MOVE

9.1.1 The door does not move at all

- Check that the power is ON. The POWER LED must light up if D1 is connected and the circuit breaker in the elevator control panel is ON.
- Check WATCHDOG LED, switch OFF/ON or replace electronic unit in case it always lights up or blinks.
- Check that the motor and encoder wires are connected correctly (plug X4 and X10) and the motor is not overheated ($\leq 60^{\circ}\text{C}$).
- Check that the control panel is sending an Open or Close command (I1-I2/X1, Led I1, I2).
- Check if there is too high friction if door is moved manually. If the state LED flashes read the faults by using WPT, switch ON/OFF.
- Check if the the open force limitation is deactivated (S1/7 OFF).

9.1.2 The door does not open

- Check that the OPEN command LED I1 lits up when an open command is present (I1/X1 low).
- Check that the CLOSE command LED I2 does not light up (I2/X1 not low). A close command overrides the open command.
- Check that the landing door lock is not jammed.
- Check if the open force limitation is active (S1/7 ON) and the friction is too high.

9.1.3 The door does not close

- Check that the CLOSE command LED I2 lits up or the Input I2/X1 is switched on COM.
- The closing force may be too low (or friction too high). Turn CLOSE FORCE potentiometer slightly clockwise to increase the closing force, but watch the maximum allowed force!

9.1.4 The door only partly opens or closes

- Check that the open and close signal times (LEDs I1, I2) from the elevator controller are long enough. The door moves only as long as command is set.

9.2 THE DOOR DOES NOT REOPEN/RECLOSE

- If no automatic reopen/reclose is selected (DIP Switch S1/2 is OFF):
For reopening/reclose the elevator controller must remove the close/open command and activate the open/close command.
To reopen/reclose the door, the elevator controller must receive either a reopen/reclose request signal from the door electronics (REOPEN output 03) or from an independently wired safety device (e.g. Photocell or Curtain of Light ...).
- If automatic reopen/reclose is selected (DIP Switch S1/2 is ON):
An automatic reopen/reclose process is caused by the Input IPD or by the close/open force limiter.

 Check the following reopen devices:

- Photocell or light cell (defect or dirty).
- Closing force limiter (force adjusted too high).

9.3 FAULTS CAUSING RESET OR SWITCH OFF (STATE LED IS BLINKING)

- Over current (power stage short circuit).
- motor or encoder short circuit, open wires and/or missing signals.
- Undervoltage (supply voltage is measured and the power stage switches off if the voltage is too low).
- door mechanically blocked.
- Internal electronic fault.
- Mechanical end not found ($\geq 3,5\text{m}$).

9.4 FAULTS DECREASING PERFORMANCE OF DOOR

- Motor and/or power stage temperature too high. The software reduces the power of the motor (power stage). If temperature is nevertheless exceeding a higher limit, power stage is shut down for cooling down a certain time.
- Low voltage supply like battery drive or low line voltage supply.
- Reference switch faulty.

10. CIRCUIT DIAGRAM MIDI DRIVE (FROM 8/09) AND SUPRA DRIVE (PS MOTOR)

10.1 WITH DETECTOR (NO EN 81-20)

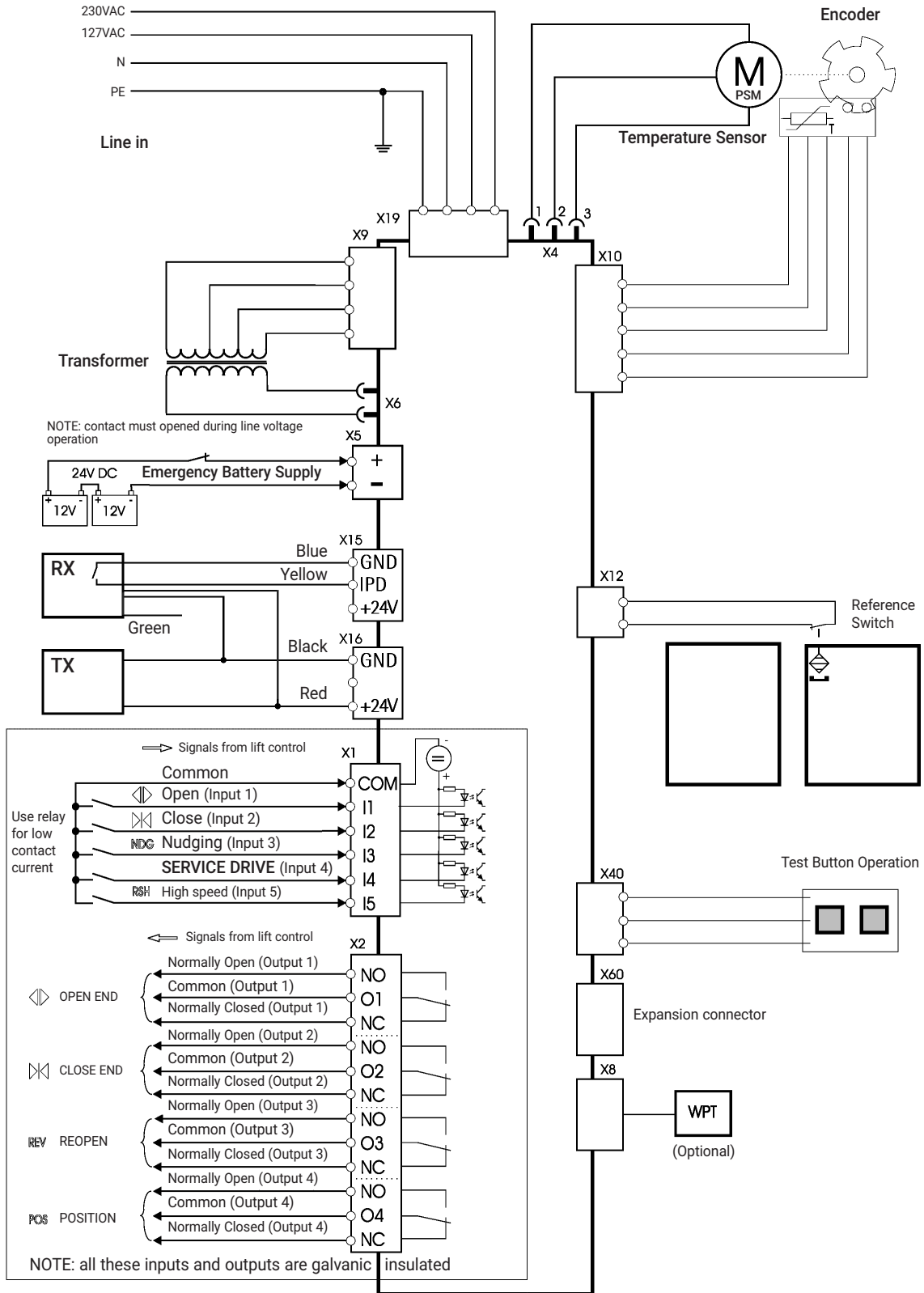

10.2 WITH W2D PHOTOCELL (NO EN 81-20)

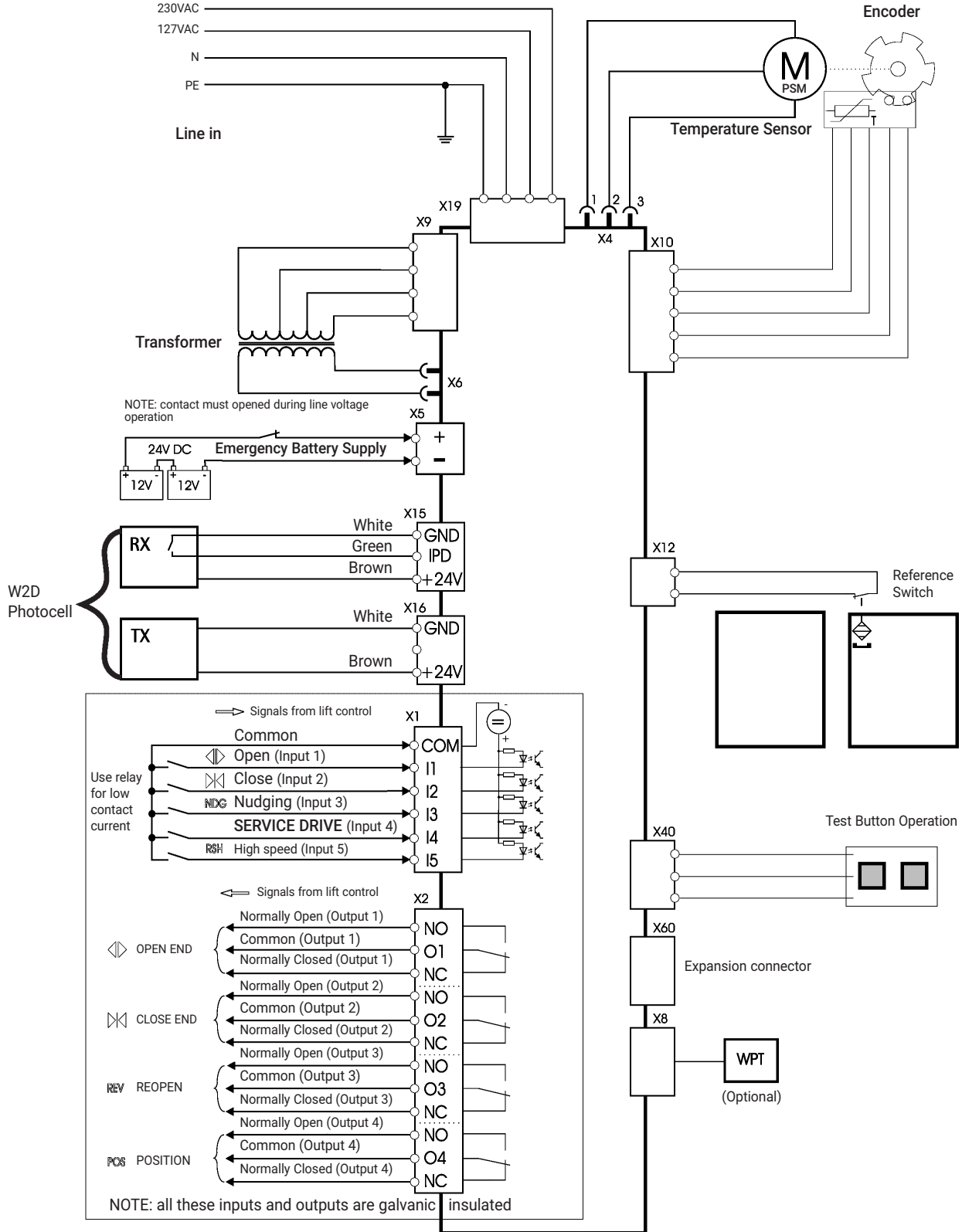

11. CIRCUIT DIAGRAM MIDI AND SUPRA DRIVE FOR EN 81-20

11.1 WITH DETECTOR EN 81-20

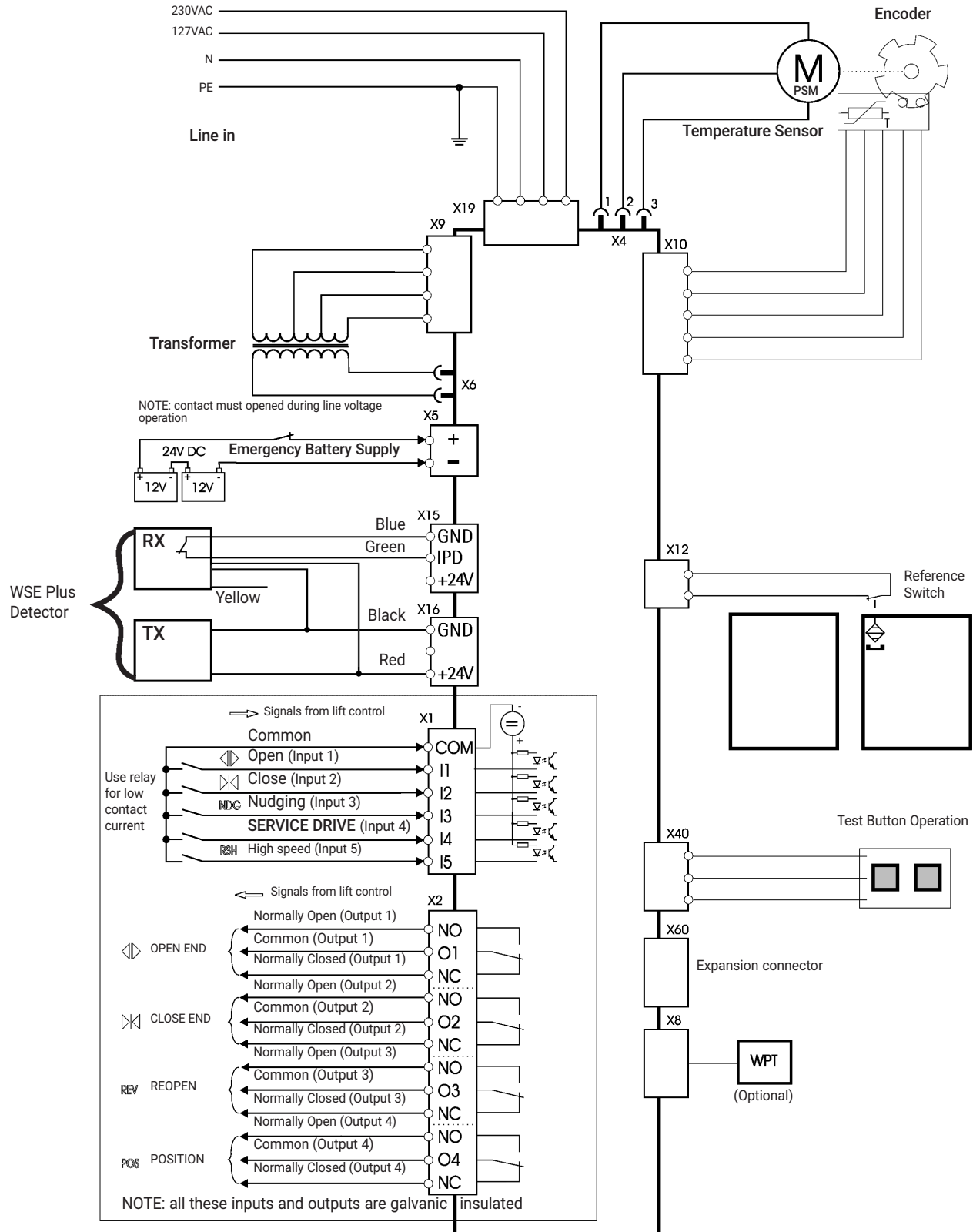

For Parameterset xE (EN81-20) the IPD input have to be always active for normal operation. If no detection device is connected to the door drive, the IPD input have to be activated by a wire bridge from IPD to GND. If a detection device is used, a normal close contact have to be connected from GND to IPD, to work with parameter set xE (EN81-20).

Subject to change without notice!

12. WITTUR PROGRAMMING TOOL - INTERFACE SOFTWARE DESCRIPTION

Valid for software revision starting from "WHD SUPRA Vx.x, dd.mm.jjjj".

12.1 INTRODUCTION

The WHD-MIDI/SUPRA-electronic is equipped with a serial communication interface RS 485 to watch/modify data stored in the electronic. Some data (for example the speed values) are stored in a memory which is independent from power supply, this memory is called EEPROM. For use of the Wittur programming Tool see Operating instructions D276Mxx.



Wrong adjustments may damage the door mechanic.

12.2 CONNECTING THE WITTUR PROGRAMMING TOOL TO THE MIDI/SUPRA-ELECTRONIC

The Programming Tool can be connected directly to the MIDI/SUPRA board at the plug X8, no further adjustments necessary. Switch off the WPT before connecting to door drive.

12.3 MENU STRUCTURE OF PROGRAMMING TOOL

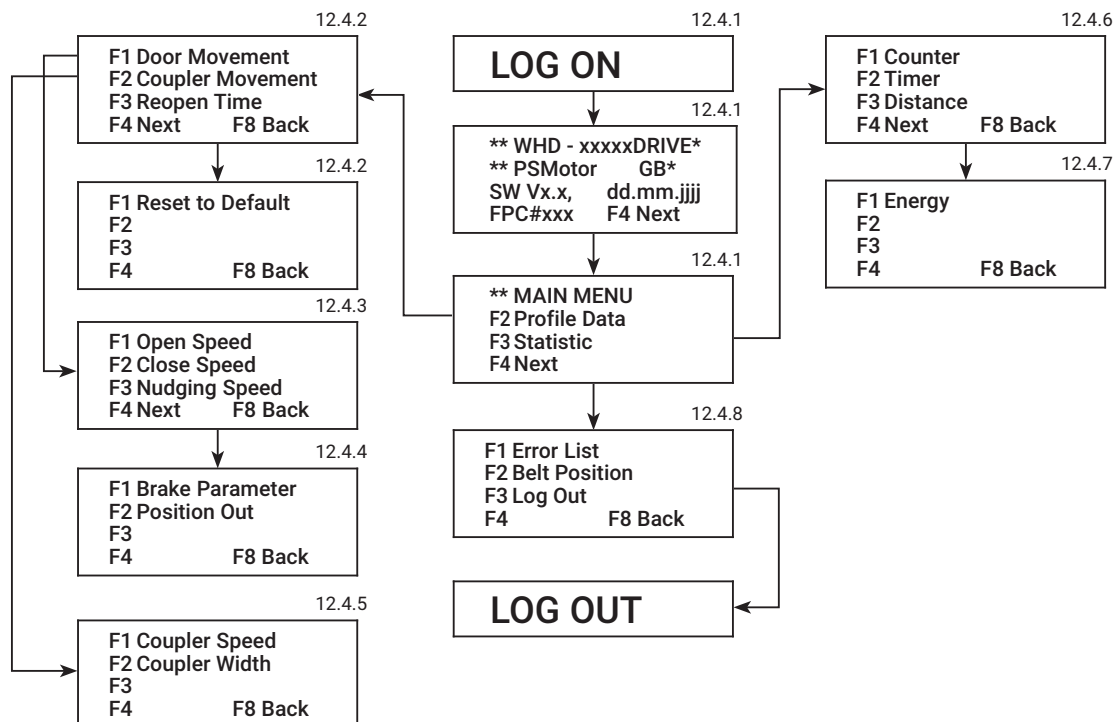

12.4 DOOR ADJUSTMENT WITH THE PROGRAMMING TOOL

12.4.1 Login of the Programming Tool

- Press the 'ON'-button longer than 2 seconds until you can see the Log-in Display.

```
WPT software V1.3
19.09.2001, 11:15

Logging on .
```

- The screen after power on login shows: motor type, language, door drive software revision and date. The user language of WPT can be changed by pressing the function buttons F1..F7 on service tool.

- Languages available:

'F1' GB English
'F2' DE Deutsch
'F3' IT Italiano
'F4' FR Français
'F5' ES Español
'F6' TR Türkce
'F7' XX Customer specific

- WHD MIDI (DC Motor)

```
* WHD - MIDI DRIVE *
* DC Motor      GB *
SW Vx.x,  dd.mm.jjjj
FPC#xxx    F8 Next
```

- WHD SUPRA (PS Motor)

```
* WHD - SUPRA RRIVE*
* PS Motor      GB *
SW Vx.x,  dd.mm.jjjj
FPC#xxx    F8 Next
```

Language

- After pressing 'F8' the initial menu screen appears.

```
** MAIN MENU
F2 Profile Data
F3 Statistic
F4 Next
```

- 'F1' shows a information screen.
- Press 'F2' or 'F3' to select one of the menu items or use 'F4' to view additional screens.

```
F1 Error List
F2 Belt Position
F3 Log Out
F4          F8 Back
```

- 'F8' jumps back to last screen.

12.4.2 'F2': Profile Data

```
F1 Door Movement
F2 Coupler Movement
F3 Reopen Time
F4          F8 Back
```

This menu allows you to call up 2 further cascading menus: 'F1' Door Movement (12.4.3) and 'F2' Coupler Movement (12.4.5).

12.4.2.1 'F3': Reopen Time

Reopen Time is the waiting period after the reopen in open end, before the door close again. By pressing 'F3' the parameter Reopen Time can be watched and changed.

```
Reopen Time:
0000.0 s

ENTER Ch.  F8 Back
```

To enter a new value press the number keys, after that press 'ENTER'. This value is taken over in a buffer and carried out.

```
Reopen Time:
0001.5 s

ENTER Ch.  F8 Back
```

By leaving this menu with 'F8' you will be asked if the entered value shall be stored permanently to the memory.

```
Use changed Value?

YES/NO      F8 Back
```

By pressing the keys 'YES' / 'NO' the value can be used / rejected.

12.4.2.2 'F4': Next (Profile Data)

```
F1 Reset to Default
F2
F3
F4          F8 Back
```

The door parameter are resetted to its initial value by pressing the button 'F1'.

12.4.2.3 'F1': Reset to default

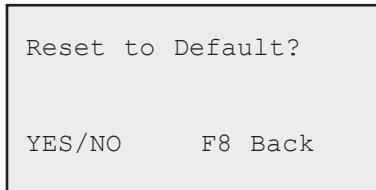

 By pressing the 'YES' button all the factory adjusted parameters are cleared and overwritten by default values.

Before resetting the door electronic to default values the two items 4.1, clause 3 and 4 must be followed (manual closing of door panels without opening of coupler!).

After the "Reset to Default" is done, continue the start-up procedure like described in item 4.1 clause 6 to 10.

12.4.3 'F1': Door Movement

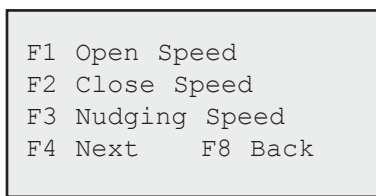

This menu allows you to watch/modify values described in the following chapters by pressing the corresponding function key.

See chapter 12.4.2.1 how to enter values.

All these variables are stored in the EEPROM. Speed values for speed setting 1-3 are calculated from values of speed setting 4 by multiplying with fix constants (see chapter 13).

12.4.3.1 'F1 Open speed' - Open speed

Top speed for open movement; speed setting 4.

12.4.3.2 'F2 Close speed' - Close speed

Top speed for close movement; speed setting 4.

12.4.3.3 'F3 Nudging speed' - Close speed for nudging

Top speed for close movement with nudging command; speed setting 4.

12.4.4 'F4': Next (Door Movement)

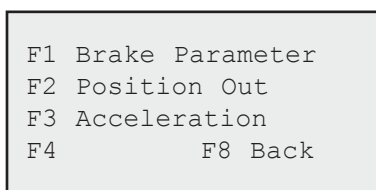

This menu allows you to watch/modify values described in the following chapters by pressing the corresponding function key.

See chapter 12.4.2.1 how to enter values.

This value is stored in the EEPROM.

Subject to change without notice!

MIDI/SUPRA

Code GM.2.001050.EN
Version F
Date 18.04.2017
Page 26.30

12.4.4.1 'Brake Parameter'

Because of the adjustment of this parameter the delay and creep to the open / close end is influenced (pre-adjusted at '5'). The possible adjustment is '0'..'9', but the earliest brake is reached with parameter '0' and the latest delay is reached with parameter '9'.

12.4.4.2 'Position Out' Relay output

By entering this parameter the Position relay can be adjusted to switch at any door position. Standard adjustment is 0 (deactivated).

12.4.4.3 'Acceleration'

By adjusting this parameter the acceleration of door can be changed. The adjustment is done in m/sec².

12.4.5 'F2': Coupler Movement

```
F1 Coupler Speed
F2 Coupler Width
F3
F4          F8 Back
```

This menu allows you to watch/modify values described in the following chapters by pressing the corresponding function key.

How to enter values see in chapter 12.4.2.1.

This value is stored in the EEPROM.

12.4.5.1 'F1 Coupler Speed'

Adjustment of the maximum speed in the coupler area. It is the same for open and close.

12.4.5.2 'F2 Coupler Width'

The parameter coupler width shows the distance which the belt is moving in close end without moving the door panels.



If this value is changed the door is stopped until the learn button is pressed!

12.4.6 'F3': Statistic

```
F1 Counter
F2 Timer
F3 Distance
F4 Next    F8 Back
```

This menu allows you to watch values described in the following chapters by pressing the corresponding function key.

12.4.6.1 'F1 Counter'

This counter shows the number of the driven door cycles.

12.4.6.2 'F2 Timer'

This counter shows the power-on time of the door electronic.

Subject to change without notice!

12.4.6.3 'F3 Distance'

This counter measures the absolute movement of the drive belt in meter, but not the coupler movement. (= distance the rollers have moved)

12.4.7 'F4': Next (Statistic)

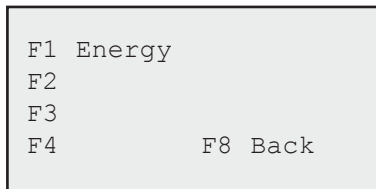

This menu allows you to watch values described in the following chapters by pressing the corresponding function key.

12.4.7.1 'F1 Energy'

This counter counts the electric power feed to the drive in KWh.

12.4.8 'F4': Next (Main Menu)

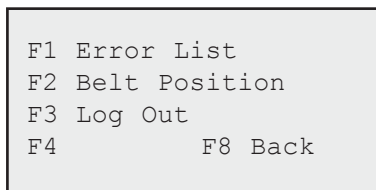

This menu allows you to watch values described in the following chapters by pressing the corresponding function key.

12.4.8.1 'F1 Error List'

Errors are coded with numbers or letters. The Error List can be deleted with the key 'F5' .

Possible Faults are:

- 'EE' : EEprom writing or reading fault
- 'OC' : Over current
- 'RS' : Faulty reference switch
- 'IE' : Internal software fault
- 'AP' : Fault by position counter, door width > 3,5m
- 'TS' : Faulty temperature sensor
- 'NE' : Encoder not connected
- 'CF' : Closing force potentiometer defect
- 'ME' : Fault by motor or encoder
- 'SS' : Standstill fault, door is blocked
- TH' : Temperature of the electronic or motor too high
- 'FE' : Is set during manual change of coupler movement parameter.
- 'ES' : Fault by Encoder, signals out of limits
- 'BE' : Electrical error during rotor angle detection, no current is flowing (Motor not connected)
- 'BM' : Mechanical error during rotor angle detection (door is stalled, or rotation direction is wrong -> press learn button)
- 'PS' : parameter set error.

12.4.8.2 'F2 Belt Position'

Actual position of the belt, positive- door panels open (then it is the door panel position), negative - coupler area.

12.4.8.3 'F3 Log Out'

By pressing F3 the communication between door drive and WPT is stopped and the WITTUR Programming Tool switches off.

13. DEFAULT ADJUSTMENT OF MIDI/SUPRA SOFTWARE

The max. close (nudging) speed must always be set according codes. EN81 requires the energy limit of $E = 10J$ for closing ($E = 4J$ for nudging), this must be calculated by the formula

$$E = \frac{m_{\text{equ}} * v_{\text{belt}}^2}{2}$$

Because of the different speeds of door panels (e.g. for telescopic doors) the mass m_{equ} has to be calculated as virtual mass seen from belt.

$$m_{\text{equ}} = m_{\text{antr}} + \text{sum of } (m_{\text{panel}} * (v_{\text{panel}} / v_{\text{belt}})^2)$$

m_{antr} virtual mass of operator

m_{panel} mass of the panel

v_{panel} speed of the panel

v_{belt} speed of the belt

The operator mass m_{operator} is about 30kg (motor, hanger plate and coupler).

The table below shows the default parameters for different speed settings. Close and nudging speeds are calculated according EN81 energy limitation (Max. mass = m_{equ}).

The max. door speed setting is calculated with mass m_{equ} of 150kg. The close and nudging speed is then limited to the panel energy of 10J and 4J respectively.

This door time will also vary depending on:

- Door masses.
- Friction.
- Mechanical adjustments.
- Alignment of landing doors.
- User Interface SW parameters.

The time for coupler and lock movement is about 0.5 sec. in open and close direction (it depends also on various different coupler types).

13.1 DEFAULT ADJUSTMENTS FOR MIDI DRIVE

| Speed adjust. (acc. EN81) | Max. mass [kg] | Open speed [m/s] | Close speed [m/s] | Nudging speed [m/s] | Acceleration [m/s ²] |
|------------------------------|-------------------|---------------------|----------------------|------------------------|-------------------------------------|
| 1 | 300 | 0,300 | 0,183 | 0,115 | 0,773 |
| 2 | 250 | 0,400 | 0,224 | 0,141 | 1,159 |
| 3 | 200 | 0,500 | 0,283 | 0,179 | 1,71 |
| 4 | 150 | 0,600 | 0,365 | 0,231 | 2,281 |

13.2 DEFAULT ADJUSTMENTS FOR SUPRA DRIVE

| Speed adjust. (acc. EN81) | Max. mass [kg] | Open speed [m/s] | Close speed [m/s] | Nudging speed [m/s] | Acceleration [m/s ²] |
|------------------------------|-------------------|---------------------|----------------------|------------------------|-------------------------------------|
| 1 | 600 | 0,300 | 0,182 | 0,115 | 0,773 |
| 2 | 400 | 0,500 | 0,224 | 0,141 | 1,159 |
| 3 | 250 | 0,700 | 0,283 | 0,179 | 1,855 |
| 4 | 150 | 0,900 | 0,365 | 0,231 | 3,091 |

WARNINGS ON HOW TO KEEP THE DOORS IN GOOD OPERATING CONDITIONS



In order to prevent failures or incorrect operation and to maintain the system in good conditions, the technical efficiency of the system should periodically be checked, to ensure compliance with the applicable laws.

The technical efficiency depends on various factors such as:

- Work load
- Years of operation
- Door weight
- Climatic and environmental conditions
- Cleanness of environment
- Correct maintenance
- Etc.

And it can affect:

- Clearance/interference between the doors, and between the doors and posts according to the applicable laws
- Clearance of coupling device
- Status/conditions of fixing and coupling elements
- Conditions of parts affected by wear
- Efficiency of the lock and relevant contacts
- Any other parts that may be affected by the type of application.

For these reasons it is not possible to establish a general part replacement programme beforehand.



All screws used for the assembly of our product are screwed by means of a tightening torque as shown on following table:

| Screw | Max torque (Nm) | Min torque (Nm) |
|-------|-----------------|-----------------|
| M3 | 1,1 | 0,9 |
| M4 | 2,6 | 2,1 |
| M5 | 5,1 | 4,1 |
| M6 | 9 | 7 |
| M8 | 21 | 17 |
| M10 | 42 | 34 |
| M12 | 71,4 | 57,1 |

In case of need please refer to above table.



WITTUR

YOUR GLOBAL PARTNER FOR COMPONENTS,
MODULES AND SYSTEMS IN THE ELEVATOR INDUSTRY

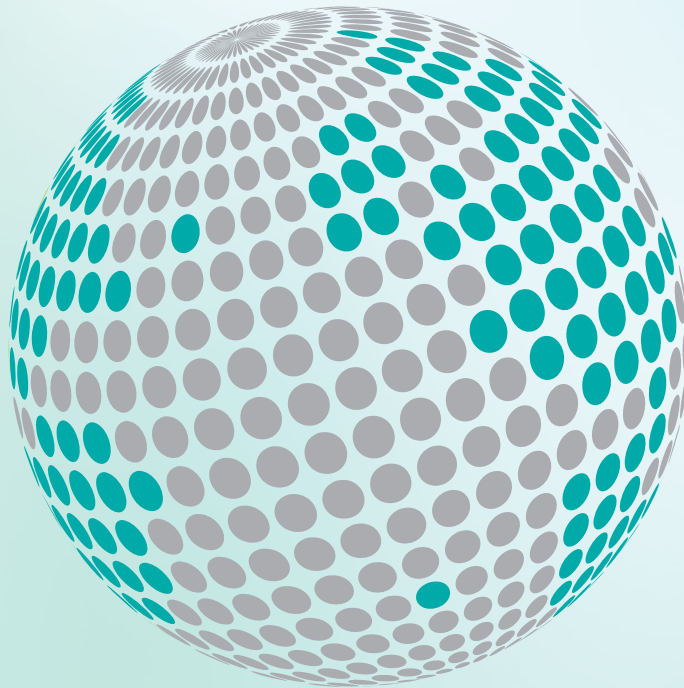

sematic[®]
a WITTUR brand

Liftmaterial
a WITTUR brand

safety **in** *motion*[™]

www.wittur.com

More information
about Wittur Group
available on-line.

